

SECTION I – CHARACTERISTICS
 SUPPRESSORS
 SPORTING ARMS & AMMUNITION MANUFACTURERS' INSTITUTE

THREAD & SOCKET DRAWINGS: CFR: .500-28-UNEF-2A /
 .500-28-UNEF-2B; ≤.225 BORE DIAMETER

ISSUED 06/07/2022
 Revised

CFR: .500-28-UNEF-2A; ≤.225 (5.72) BORE – MUZZLE/SHOULDER INDEX

SHEET 1 OF 3

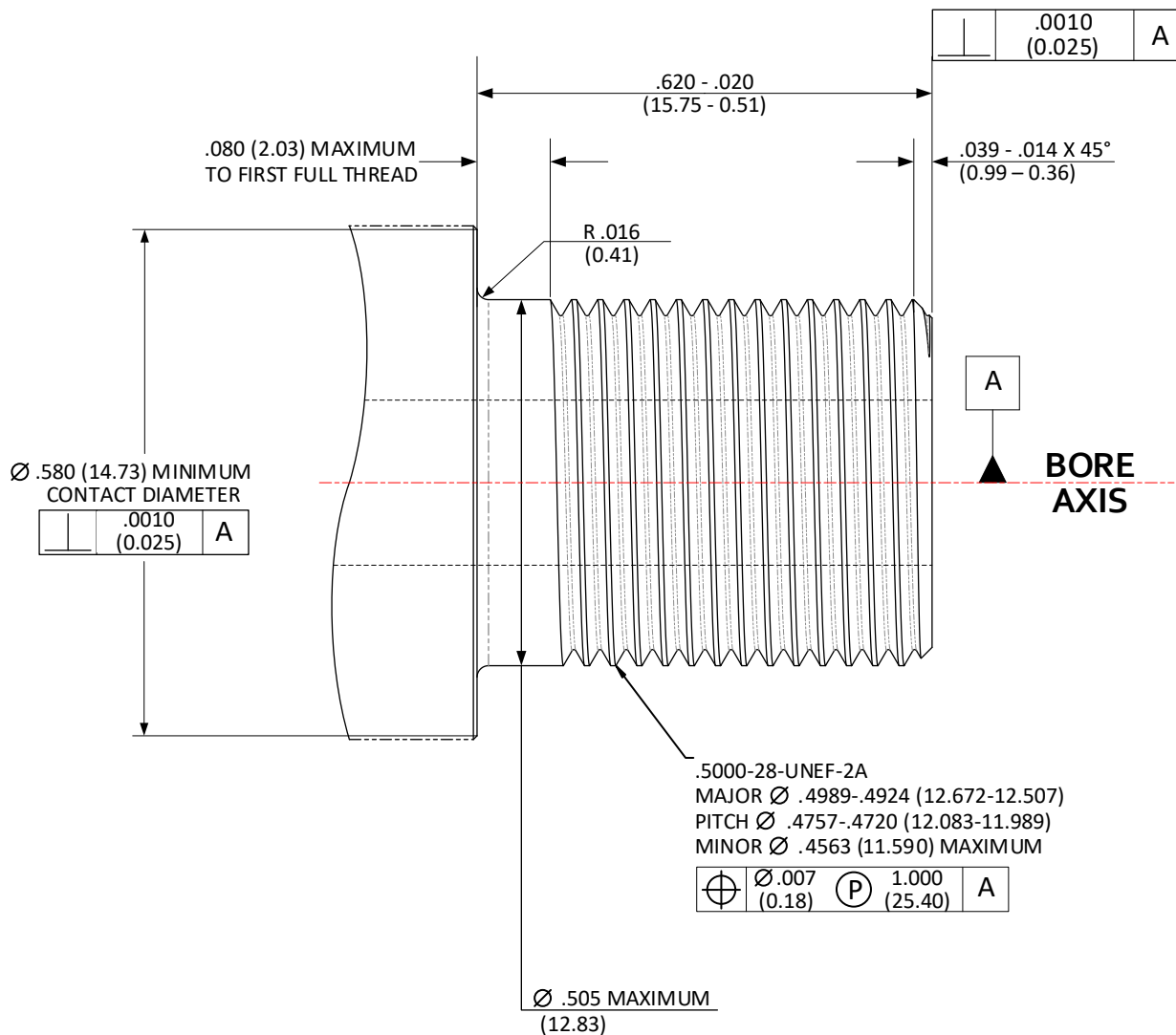

DO NOT SCALE FROM DRAWING

NOTES:

DATUM "A" FEATURE IS DEFINED AS THE LAST 3.0000 INCHES (76.200) OF THE BORE AT THE MUZZLE END OF THE BARREL.
 (XX.XX) = MILLIMETERS
 DRAWING PREPARED USING THE DIMENSIONING CONVENTIONS DEFINED IN ASME Y14.5-2018.

UNLESS OTHERWISE SPECIFIED
 DIMENSIONS ARE IN INCHES

.X	±.1 (3)	ANGLES	±0.5°
.XX	±.01 (0.3)	FILLET RADII	.005-.010 (0.13-0.25)
.XXX	±.005 (0.13)	BREAK EDGE	.005-.010 (0.13-0.25)
.XXXX	±.0005 (0.013)	SURFACE FINISH	▽ (▽)

CFR: .500-28-UNEF-2A; ≤.225 (5.72) BORE – MUZZLE/SHOULDER INDEX (Cont'd)

SHEET 2 OF 3

AS REFERENCE, THE SHADED AREA REPRESENTS A ZONE INTENDED TO BE RESERVED FOR DEVICES ATTACHED TO THESE THREADS. CONSIDERATION OF INTRUSION INTO THIS VOLUME DURING THE ENTIRE FIRING CYCLE OF THE FIREARM SHOULD BE MADE.

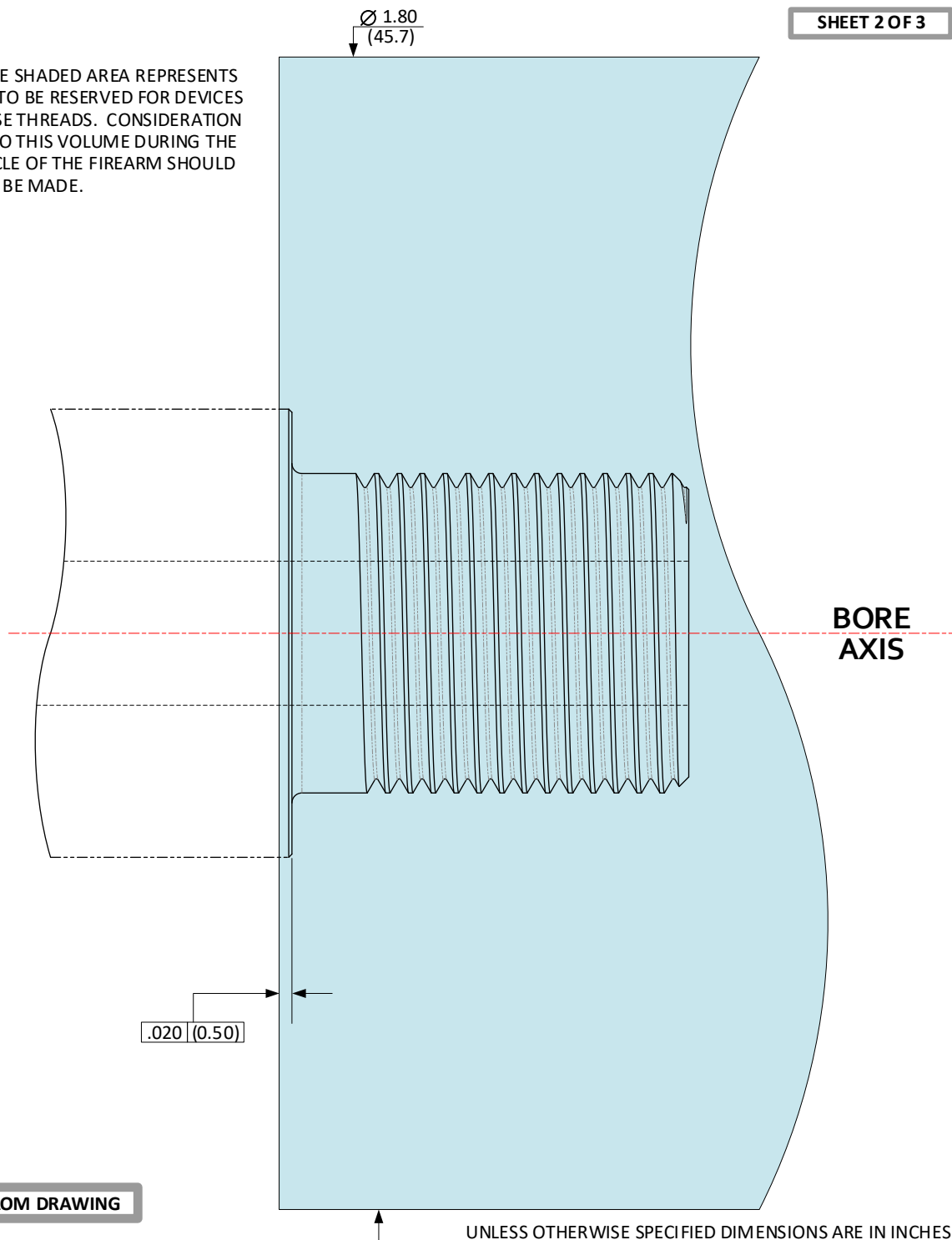

DO NOT SCALE FROM DRAWING

NOTES:
 (XX.XX) = MILLIMETERS
 DRAWING PREPARED USING THE DIMENSIONING
 CONVENTIONS DEFINED IN ASME Y14.5-2018.

UNLESS OTHERWISE SPECIFIED DIMENSIONS ARE IN INCHES
 .X ±.1 (3) ANGLES ±0.5°
 .XX ±.01 (0.3) FILLET RADII .005-.010 (0.13-0.25)
 .XXX ±.005 (0.13) BREAK EDGE .005-.010 (0.13-0.25)
 .XXXX ±.0005 (0.013) SURFACE FINISH $\sqrt{\text{V}}$ ($\sqrt{\text{V}}$)

SECTION I – CHARACTERISTICS
 SUPPRESSORS
 SPORTING ARMS & AMMUNITION MANUFACTURERS' INSTITUTE

THREAD & SOCKET DRAWINGS: CFR: .500-28-UNEF-2A /
 .500-28-UNEF-2B; ≤.225 BORE DIAMETER

ISSUED 06/07/2022
 Revised

CFR: .500-28-UNEF-2B; ≤.225 (5.72) BORE – MUZZLE/SHOULDER INDEX (Cont'd)

SHEET 3 OF 3

DO NOT SCALE FROM DRAWING

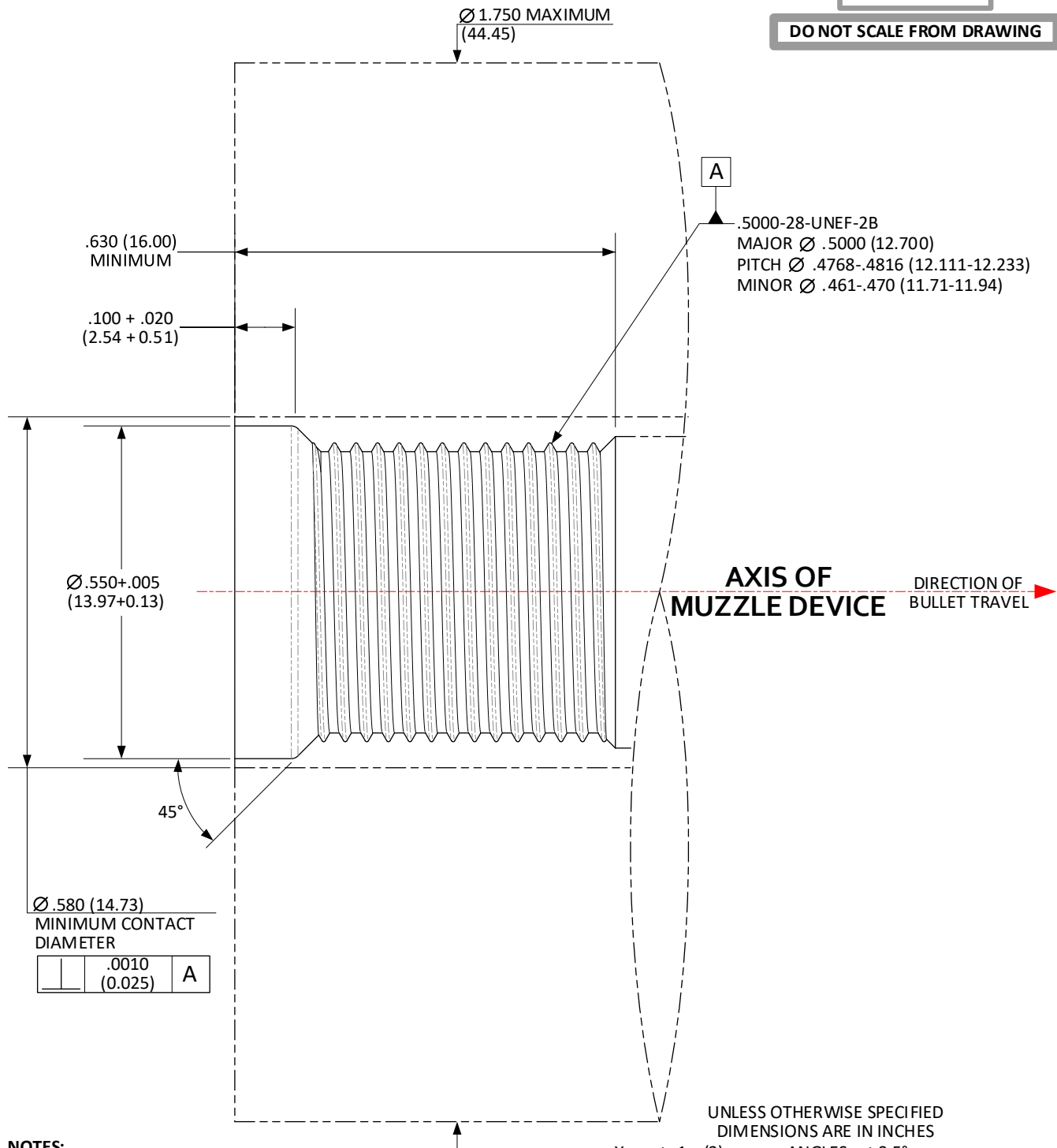

NOTES:
 (XX.XX) = MILLIMETERS
 DRAWING PREPARED USING THE DIMENSIONING CONVENTIONS DEFINED
 IN ASME Y14.5-2018.

.X ±.1 (3) ANGLES ±0.5°
 .XX ±.01 (0.3) FILLET RADII .005-.010 (0.13-0.25)
 .XXX ±.005 (0.13) BREAK EDGE .005-.010 (0.13-0.25)
 .XXXX ±.0005 (0.013) SURFACE FINISH $\sqrt{\quad}$ ($\sqrt{\quad}$)