

CFP&R: .500-28-UNEF-2A; ≤.355 (9.02) BORE – MUZZLE THREADS

SHEET 1 OF 5

NOTE: IF THE MINIMUM SHOULDER CONTACT DIAMETER CANNOT BE ACHIEVED, MUZZLE INDEXING MUST BE USED.

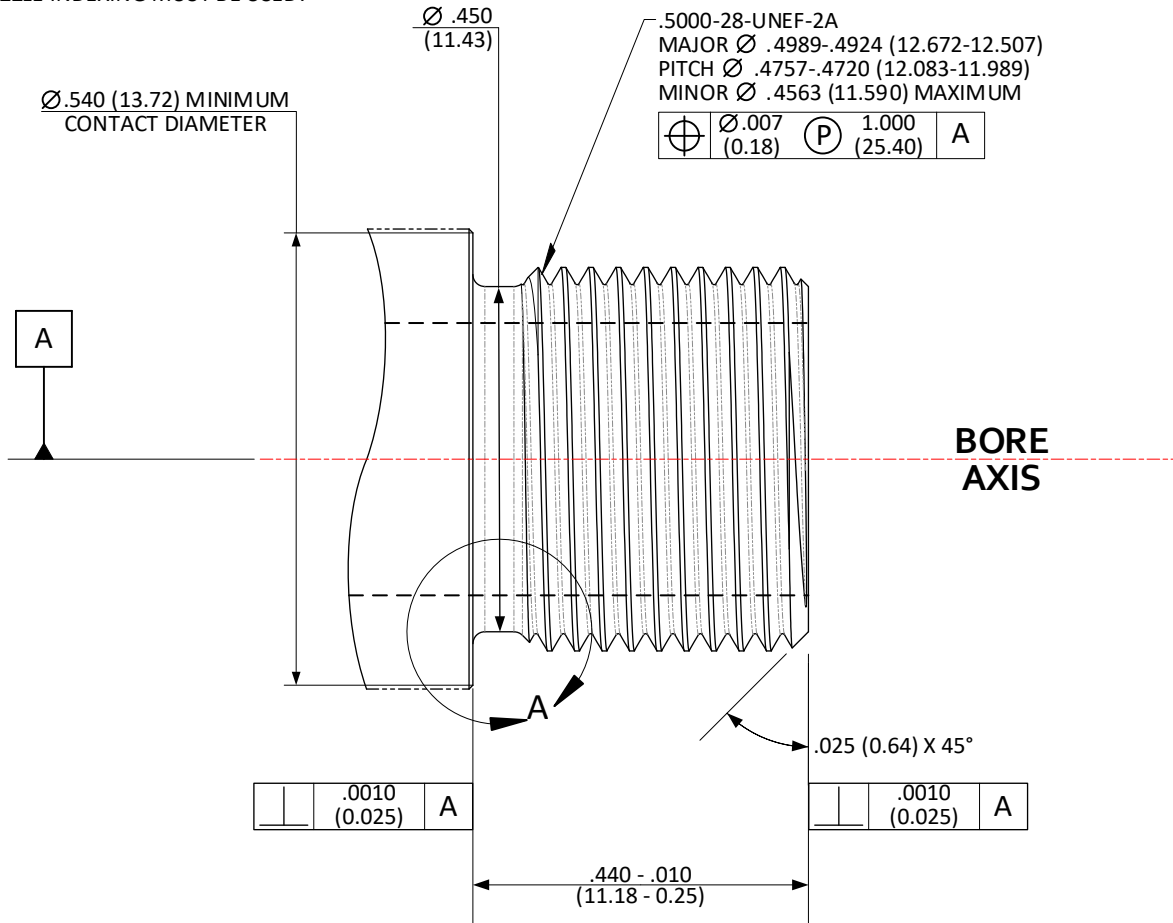

DO NOT SCALE FROM DRAWING

NOTES:
 DATUM "A" FEATURE IS DEFINED AS THE LAST $\boxed{3.0000}$ INCHES $\boxed{[76.200]}$
 OF THE BORE AT THE MUZZLE END OF THE BARREL.
 (XX.XX) = MILLIMETERS
 DRAWING PREPARED USING THE DIMENSIONING CONVENTIONS DEFINED
 IN ASME Y14.5-2018.

UNLESS OTHERWISE SPECIFIED DIMENSIONS ARE IN INCHES
 .X $\pm .1 (3)$ ANGLES $\pm 0.5^\circ$
 .XX $\pm .01 (0.3)$ FILLET RADII $.005-.010 (0.13-0.25)$
 .XXX $\pm .005 (0.13)$ BREAK EDGE $.005-.010 (0.13-0.25)$
 .XXXX $\pm .0005 (0.013)$ SURFACE FINISH $\sqrt{\text{V}}$ ($\sqrt{\text{V}}$)

CFP&R: .500-28-UNEF-2A; ≤.355 (9.02) BORE – MUZZLE THREAD DETAIL

SHEET 2 OF 5

DETAIL A

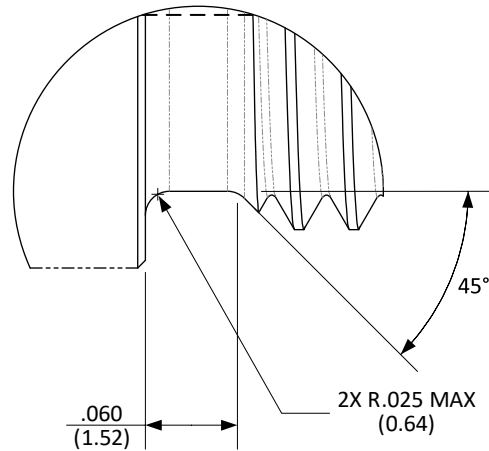

DO NOT SCALE FROM DRAWING

UNLESS OTHERWISE SPECIFIED DIMENSIONS ARE IN INCHES

NOTES:
(XX.XX) = MILLIMETERS
DRAWING PREPARED USING THE DIMENSIONING CONVENTIONS DEFINED
IN ASME Y14.5-2018.

.X ± .1 (3)	ANGLES ± 0.5°
.XX ± .01 (0.3)	FILLET RADII .005-.010 (0.13-0.25)
.XXX ± .005 (0.13)	BREAK EDGE .005-.010 (0.13-0.25)
.XXXX ± .0005 (0.013)	SURFACE FINISH $\sqrt{\text{X}}$ ($\sqrt{\text{X}}$)

CFP&R: .500-28-UNEF-2A; ≤.355 (9.02) BORE – EXCLUSION ZONE

SHEET 3 OF 5

AS REFERENCE, THE SHADED AREA REPRESENTS A ZONE INTENDED TO BE RESERVED FOR DEVICES ATTACHED TO THESE THREADS. CONSIDERATION OF INTRUSION INTO THIS VOLUME DURING THE ENTIRE FIRING CYCLE OF THE FIREARM SHOULD BE MADE.

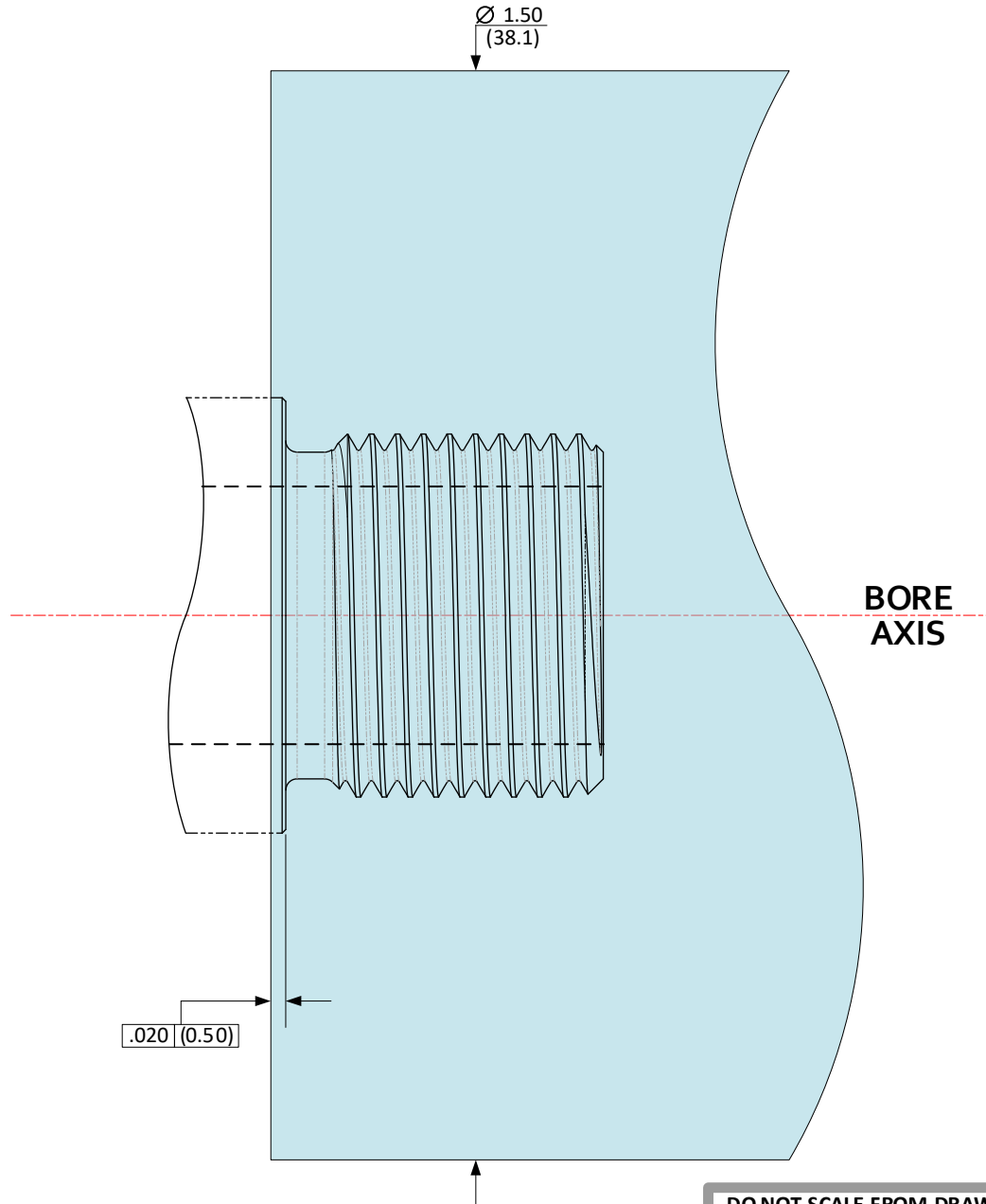

DO NOT SCALE FROM DRAWING

NOTES:
 (XX.XX) = MILLIMETERS
 DRAWING PREPARED USING THE DIMENSIONING CONVENTIONS DEFINED
 IN ASME Y14.5-2018.

UNLESS OTHERWISE SPECIFIED DIMENSIONS ARE IN INCHES
 .X ± .1 (3) ANGLES ± 0.5°
 .XX ± .01 (0.3) FILLET RADII .005-.010 (0.13-0.25)
 .XXX ± .005 (0.13) BREAK EDGE .005-.010 (0.13-0.25)
 .XXXX ± .0005 (0.013) SURFACE FINISH $\sqrt{\text{V}}$ ($\sqrt{\text{V}}$)

**CFP&R: .500-28-UNEF-2B; ≤.355 (9.02) BORE –
 SOCKET THREADS; SHOULDER INDEXING**

SHEET 4 OF 5

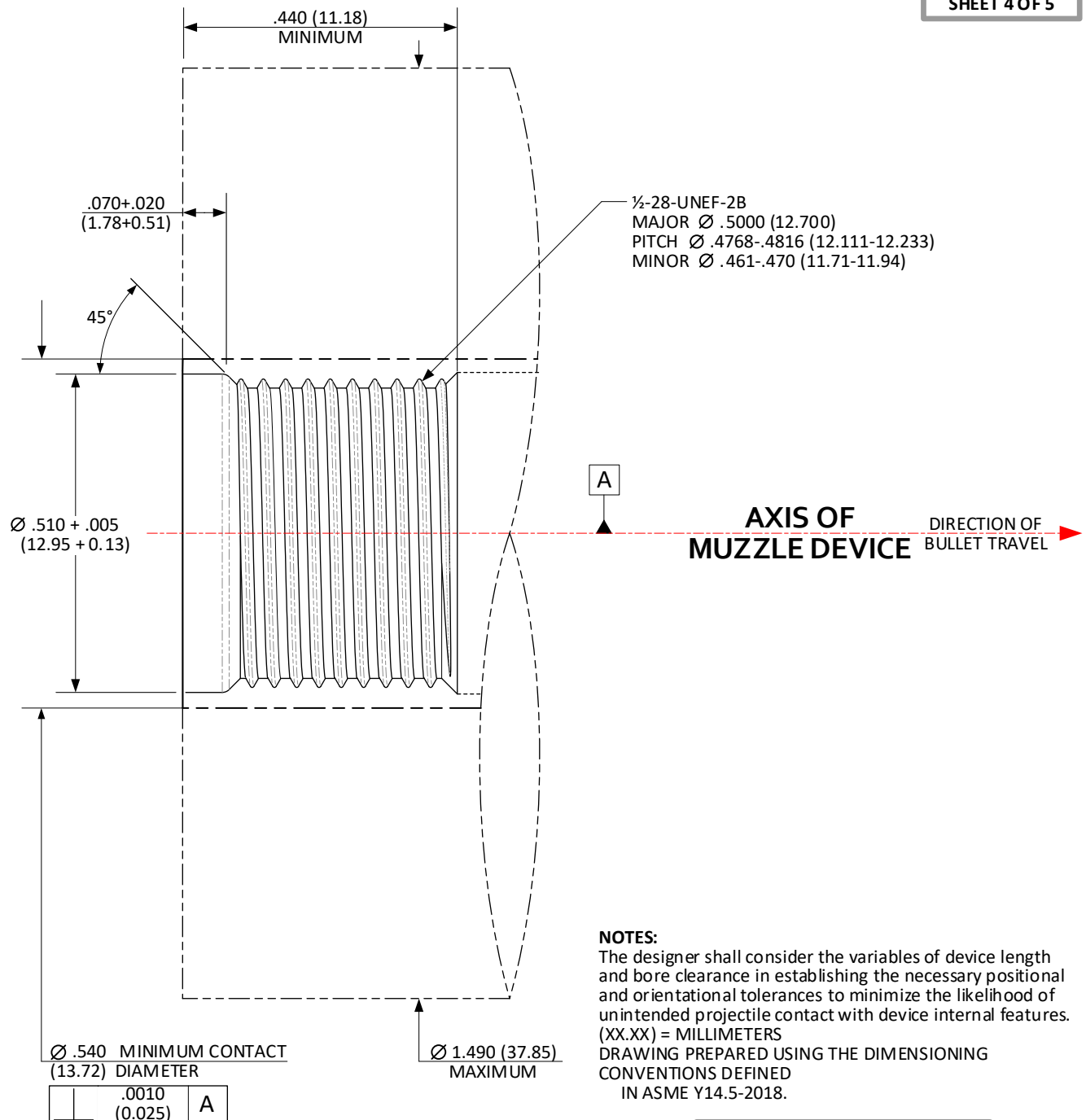

DO NOT SCALE FROM DRAWING

UNLESS OTHERWISE SPECIFIED DIMENSIONS ARE IN INCHES

- .X $\pm .1 (3)$ ANGLES $\pm 0.5^\circ$
- .XX $\pm .01 (0.3)$ FILLET RADII $.005 - .010 (0.13 - 0.25)$
- .XXX $\pm .005 (0.13)$ BREAK EDGE $.005 - .010 (0.13 - 0.25)$
- .XXXX $\pm .0005 (0.013)$ SURFACE FINISH $\sqrt{\text{A}}$ ($\sqrt{\text{A}}$)

**CFP&R: .500-28-UNEF-2B; ≤.355 (9.02) BORE –
 SOCKET THREADS; MUZZLE INDEXING**

SHEET 5 OF 5

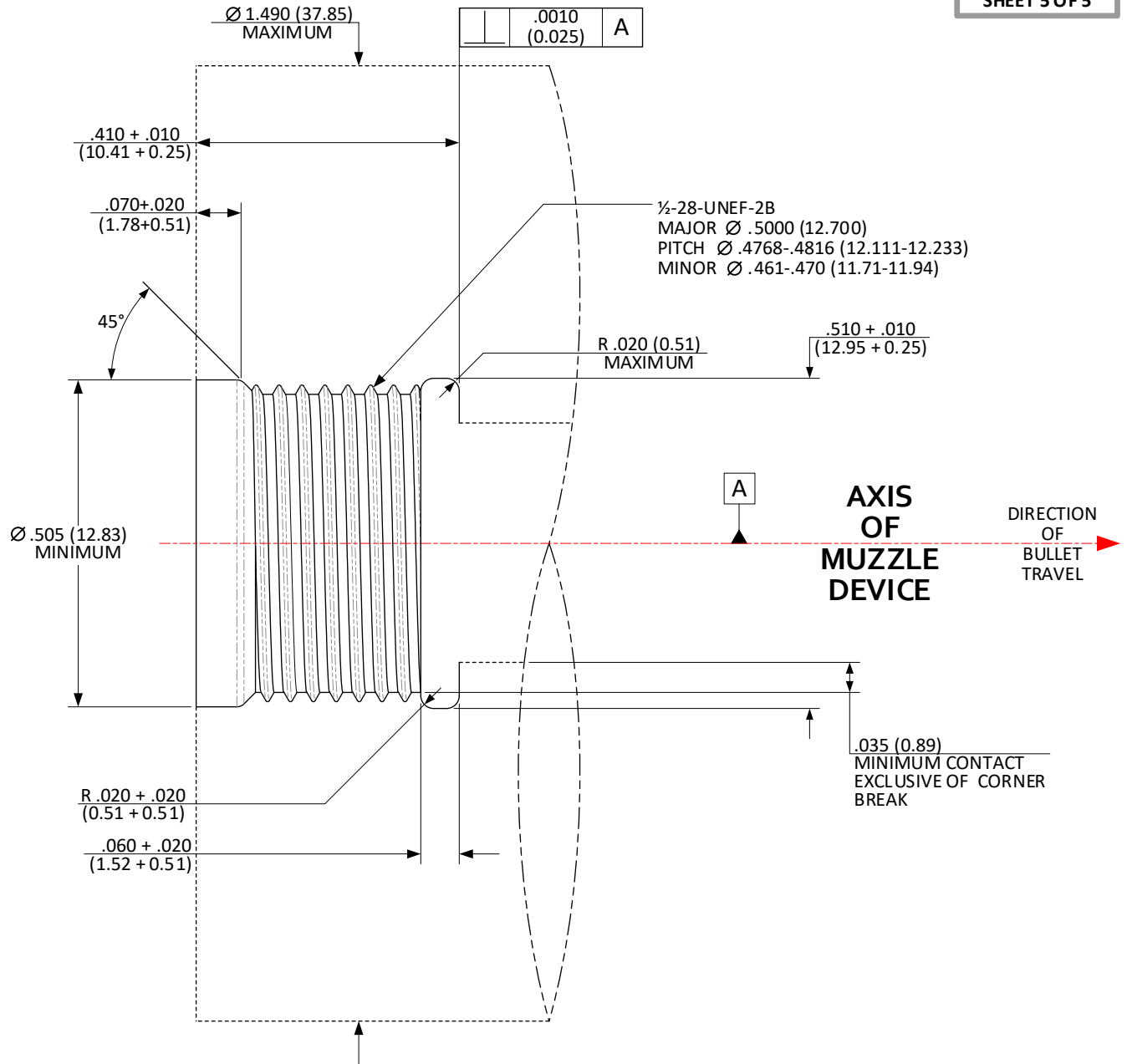

NOTES:
 The designer shall consider the variables of device length and bore clearance in establishing the necessary positional and orientational tolerances to minimize the likelihood of unintended projectile contact with device internal features.
 (XX.XX) = MILLIMETERS
 DRAWING PREPARED USING THE DIMENSIONING CONVENTIONS DEFINED IN ASME Y14.5-2018.

DO NOT SCALE FROM DRAWING

UNLESS OTHERWISE SPECIFIED DIMENSIONS ARE IN INCHES
 .X ±.1 (3) ANGLES ±0.5°
 .XX ±.01 (0.3) FILLET RADII .005-.010 (0.13-0.25)
 .XXX ±.005 (0.13) BREAK EDGE .005-.010 (0.13-0.25)
 .XXXX ±.0005 (0.013) SURFACE FINISH ∇ (∇)